

Use and Care

Instructions

for your new



High Head
Micro-hydroelectric Generator



Models: MHG-200HH
MHG-500HH

READ THIS FIRST

This manual contains important information concerning your new PowerPal high head micro-hydroelectric generator. It covers Models MHG-200HH and MHG-500HH. You should read this manual carefully before installing PowerPal or allow a trained technician from your local PowerPal Service Center to install it for you.

Your PowerPal generator is designed to be simple to operate and easy to maintain. If used in accordance with these instructions your PowerPal will give you many years of service. PowerPal is also designed with safety in mind, but any electric device can be dangerous if not used correctly. At several points in this manual, instructions requiring special attention that must be followed are shown as:



Warning symbol - beware of hazards or unsafe practices that may cause injury or death.



Caution symbol – beware of hazards or unsafe practices that may damage the product.

SAFETY FIRST



While electricity improves your life, it can also be dangerous if simple precautions are not followed:

- Never allow electrical contacts to become wet. Beware of electrocution.
- Never attempt to cut electrical wires or open appliances for repair if the generator is working. Unplug the main cable first.
- Inform children of the dangers of electrocution. Never allow them to play with electrical connections.
- Keep fingers away from the moving turbine runner. If partly blocked with debris, stop the water flow before cleaning.
- If you have any questions about safety, please ask your PowerPal Service Center.
- Product must be earth bonded (grounded).

OPERATING CAUTIONS



Your PowerPal generator is designed for simple operation and low maintenance. However, the following operating cautions must be followed to ensure a long life for PowerPal:

- Under conditions of higher water heads than given for each model in this manual, PowerPal is able to generate higher power outputs than rated. This can also occur if the intake pipe diameter exceeds the recommended diameter. If maximum power consumption listed in this manual is exceeded then the copper coils in PowerPal may be irreparably damaged and require total rewiring. See the section on ‘Technical Specifications’.
- Do not forget to grease the bearings at the recommended times. Failure to do this will result in excessive wear on the bearings and shorten their life. Always ensure that the Electronic Load Controller is set at approximately 220V. Otherwise, the life of lights and appliances may be reduced.

- Low frequencies will result if the generator rotor is rotating slower than usual. Low frequencies may prevent proper functioning of appliances such as televisions and will harm electric motors. PowerPal is designed to stop working if the rotor speed becomes too low, as the drag on the rotor becomes too great to sustain its rotation. This in-built mechanism is there to avoid problems associated with low frequencies. High frequencies will occur if the rotor is rotating faster than usual. This is due to either a high head or water flow rate or the use of a small load. It can be corrected by adjusting the spear valve, or by turning on another appliance to increase the load. Sustained high frequencies may overheat some electric motors or affect television picture quality. Light bulbs are not affected by frequency but are affected by voltage.

POWERPAL COMPONENTS

Inside your PowerPal box you will find:

- 1 x generator-turbine assembly
- 1 x penstock adaptor flange
- 1 x electronic load controller
- 1 x replacement bearing seal
- 1 x Guarantee Card
- 1 x this instruction manual.

Please advise immediately if any parts are missing. Complete your Guarantee Card and have it signed by your PowerPal dealer.

The PowerPal system consists of two major components – a hydroelectric generator and an electronic load controller. Other components are necessary and these can be purchased locally. The penstock (intake pipe) can be made of PVC plastic (recommended), steel, reinforced concrete, fired clay waterpipe or bamboo. Your PowerPal dealer can advise you about this.

Therefore, other parts which are not included in the box but which are required to make PowerPal work are:

- a length of PVC or other pipe.
- electrical wire from generator to house. See the section on ‘Technical Specifications’ for the correct wire size.
- household wiring.

These are available from your dealer or local electrical store.

SYSTEM DIAGRAM

The following diagram shows how the non-electrical components fit together. Further reading of this manual will provide the necessary explanations. The components are:

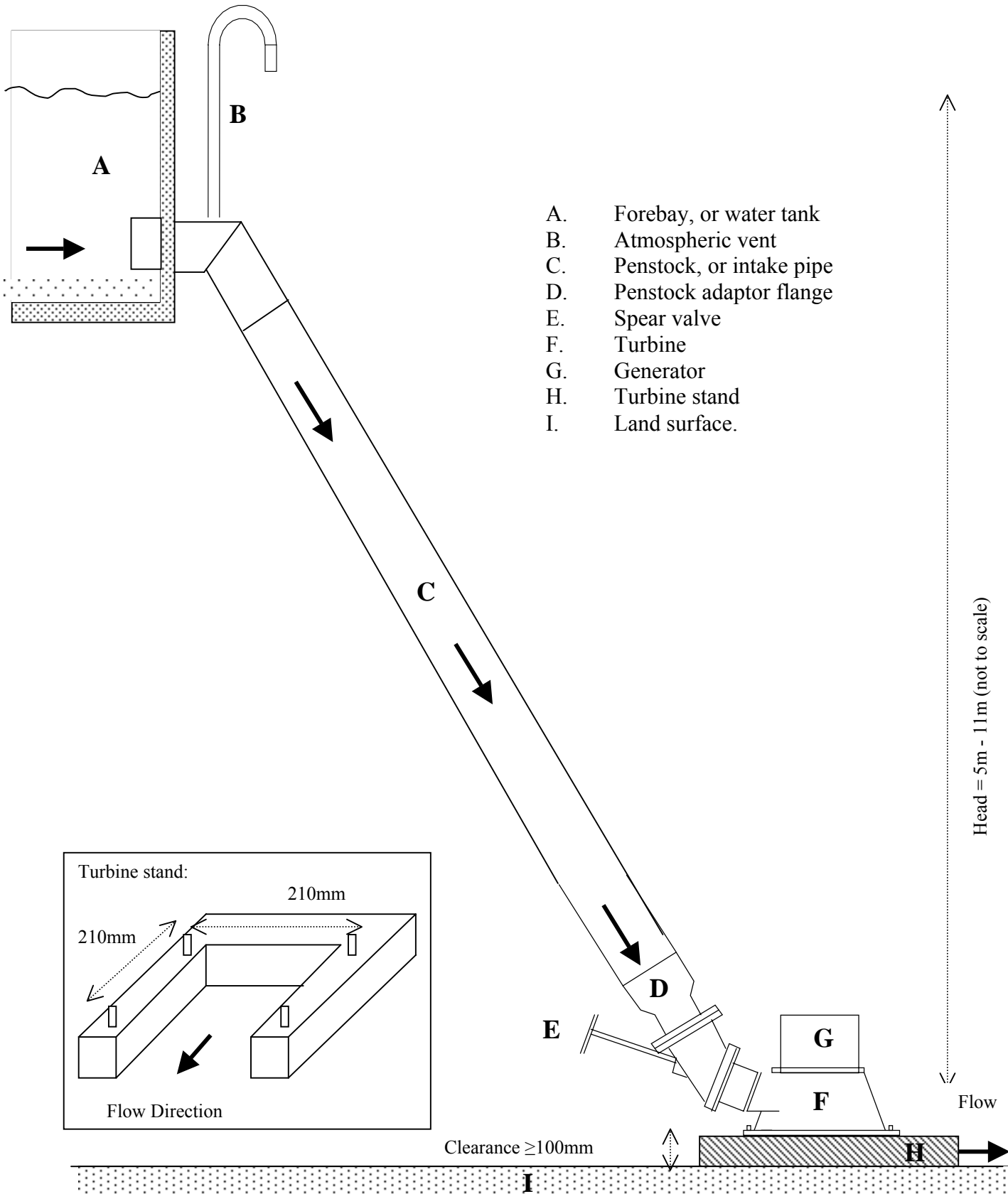

- A. Forebay, or water tank
- B. Atmospheric vent
- C. Penstock, or intake pipe
- D. Penstock adaptor flange
- E. Spear valve
- F. Turbine
- G. Generator
- H. Turbine stand
- I. Land surface.

Head = 5m - 11m (not to scale)

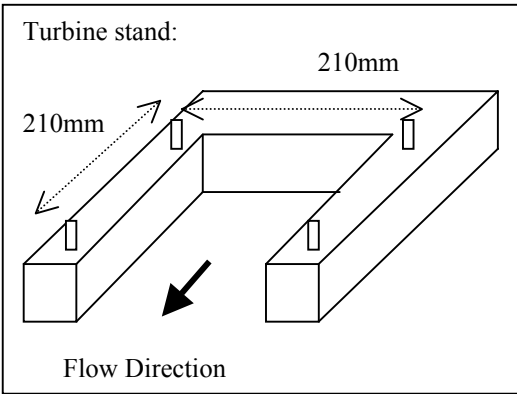

Clearance $\geq 100\text{mm}$

SELECTING A SITE

PowerPal is designed for use in a wide range of locations. There are two critical factors that influence power output – head and flow. Head is the vertical distance between the turbine and the water source (forebay), measured in meters. Flow is the amount of water that passes through the turbine at any instant, measured in litres per second (l/sec). The following table shows the various combinations of head and flow to achieve certain maximum power outputs for each model:

| Turbine | MHG-200HH | | MHG-500HH | | | | |
|-----------------------|-----------|-----|-----------|-----|-----|-----|-----|
| Water head H (m) | 5 | 6 | 7 | 8 | 9 | 10 | 11 |
| Water flow Q (l/sec.) | 6.3 | 6.4 | 7.4 | 7.9 | 8.4 | 8.9 | 9.1 |
| Power output (W) | 160 | 200 | 275 | 325 | 390 | 460 | 520 |

For example, if your site has available 11 meters of head and a water flow of 9.1 litres per second then a PowerPal MHG-500HH will produce up to 520W of electricity.

Measuring Head

The head is the height from the water surface in the forebay down to the level of the turbine. It is shown in the System Diagram. To measure this, use a tape measure and a clinometer or spirit level etc. A less accurate but useful alternative is to make your own level from a transparent tube half-filled with water. Attach this to the top of a 1m long stick and then point this horizontally at a point further up the slope as though it were a spirit level. By going to that point and repeating the process the total head can be measured – see the drawing below.

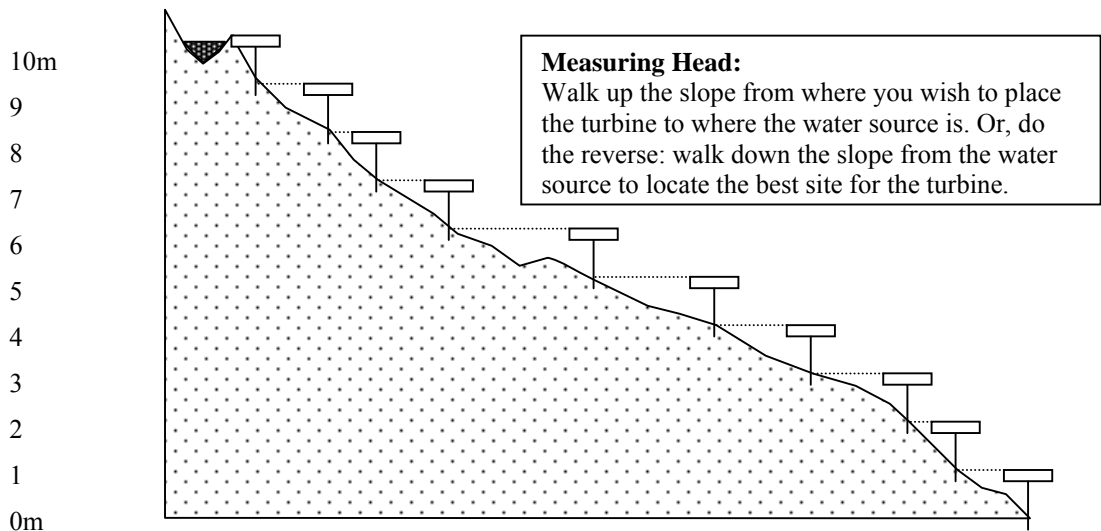

Another method is to use an accurate pressure gauge and a length of hose. Run a water-filled hose from the forebay to the turbine site and attach the pressure gauge to the bottom end. The pressure gauge shows 1.422 psi / meter of head e.g. 7.11 psi for a head of 5m to 15.64 psi for a head of 11m.

This head should be between 5 and 6 meters for the MHG-200HH model and between 7 and 11 meters for the MHG-500HH model. If it is smaller then the power output will be reduced. If it is larger then your power output will be increased. While

increased power output appears desirable, if the head is too large then the rotor will turn too fast and reduce the life of the bearings. For heads less than 6 meters a MHG-200HH is the recommended model and for heads greater than 6 meters the MHG-500HH is required.



Do not attempt to exceed the recommended head height.

Measuring Flow

The best way to measure the water flow is to take a piece of pipe the same diameter as the penstock, insert it in the stream or dam where the flow is expected to come from, and measure the flow from there.

In the diagram below, a short length of pipe (less than 1 meter) is buried into the side of a small 'dam' using mud or improvised sandbags. The top end of the pipe is completely submerged and part of the normal stream flow is diverted through the pipe. When this is flowing smoothly, a bucket of known volume is quickly placed to collect this flow and the time it takes to fill the bucket is recorded. The ideal bucket size would be 100 or 200 litres (half or a whole empty oil drum), but smaller buckets will work. Divide the volume of the bucket (in litres) by the time it takes to fill the bucket (in seconds) to get the approximate flow rate in litres per second.

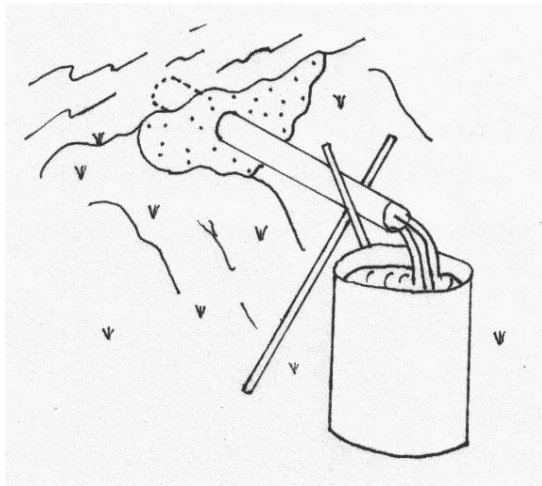

Measuring Flow:

$$\text{Flow} = \frac{\text{volume of bucket (litres)}}{\text{time to fill bucket (seconds)}}$$

SITE PREPARATION

Once the correct head and flow have been located then the length and position of the penstock can be determined. While vertical head is important, the horizontal slope and penstock length may vary.

A good way to reduce penstock length is shown in the following diagram.

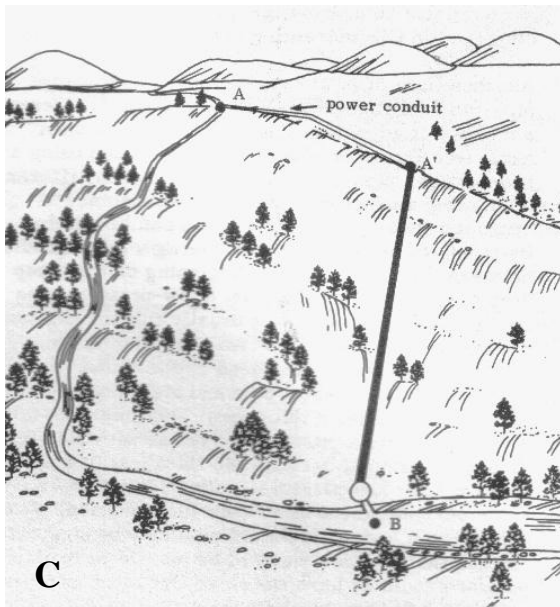
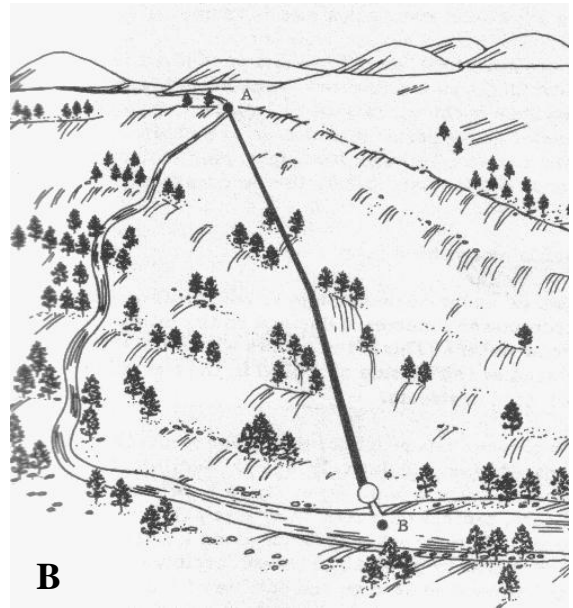
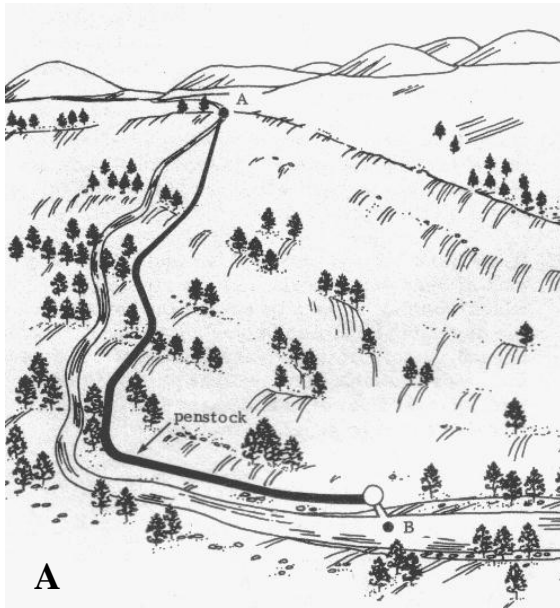

The penstock is shown by the black line A-B. In the first diagram (A) the penstock follows the stream. This may lead to unnecessary length and cost. In diagram B, the most direct route is selected to reduce length and cost. Diagram C shows the best alternative where a side channel or 'power conduit' is cut into the side of the hill. This carries the water to a point as close to above the turbine as possible and best reduces the length of penstock required.

The power conduit roughly follows the hill's contour and need only be a simple ditch say 30cm x 30cm in section.

When installing the penstock, try to keep it as straight as possible and avoid sharp turns or angles. To do this, part of the hillslope may need excavating while in other places the penstock may need supporting with poles etc. Steeper terrain has advantages over more gentle terrain as cost is reduced by the use of a shorter penstock.

The forebay, or water holding tank at the top of the penstock can be as simple as a deep part of a flowing stream or power conduit. It is a good idea to give some permanence to this structure so that a constant water source is available and so the top of the penstock is always submerged. A small dam is the best method and need only be 1 meter high. The top of the penstock is typically placed not at the bottom but some way up the dam wall so that the bottom of the dam acts as a sink for rotting leaf litter, deposited sand and mud etc. This sink may need periodic cleaning out. Another good idea is to cover the end of the penstock with a piece of wire mesh (debris screen) to keep leaves etc. from flowing in and clogging the turbine. See Appendix A for the ideal forebay design.

SYSTEM INSTALLATION

After locating a suitable site and completing the earthworks (if any), your PowerPal is ready for installation. To do this:

1. Bolt the turbine to a turbine stand or base which allows at least 100mm clearance between the turbine and the ground. The turbine stand should be sturdy and made from concrete or steel as shown on page 4 of this manual. Bolt spacing is 210mm as shown in the diagram.
2. Bolt the turbine to the penstock adaptor flange (A – see below). The optimal diameter of the penstock and PVC fittings is 110mm, to produce the most power. The minimum diameter is 76mm but less power output may be expected.
3. Turn the handle of the spear valve anticlockwise until the valve is fully open.



Always turn the handle slowly and smoothly.

4. Affix a 135° (or other) elbow bend of PVC into the forebay wall. This should be fitted with an atmospheric vent (hollow bent pipe), which allows air to escape from the penstock. The upper opening of the atmospheric vent should be higher than the water level in the forebay. Divert water away from the forebay or else block the top of the penstock pipe during the installation procedure.
5. Start installing the penstock. Assembly can begin from either direction but it is usually easier to begin uphill – the turbine is much easier to move around than the forebay is. The penstock should be well secured i.e. supported or buried at regular intervals to support its weight when full – this is particularly important at the bottom of the penstock so that PowerPal cannot be knocked over. At least two people should handle the penstock, one uphill and one downhill, until it is fitted into both the elbow bend and the penstock adaptor flange (B). If PVC is used for the penstock then use PVC glue to bind the joints but note that the PVC must be dry for the glue to work.



6. Once the glue is set the turbine can be started. Fill the forebay and allow the water to flow freely into the penstock. The turbine runner will rotate and spent water will flow out in front of the turbine stand (into an escape drain). An alternative is to allow the water to escape through the floor of a purpose-built platform. Once the water is flowing freely the electrical setup may begin.

7. Earth-bond (ground) PowerPal. Do this by attaching one end of a suitable length of 0.75 sq.mm/A wire to PowerPal and the other end to a metal object or metal stake in the ground nearby PowerPal. Although the risk of electric shock is already low, this earth-bonding is still best practice.
8. Run the required length of two-strand, jacketed electrical cable from PowerPal to your house etc. Use 3.75 Ampere wire (0.75 sq. mm / Amp) for both MHG-200 and MHG-500 models. This is thicker than is required but thinner wires are more fragile. For the MHG-1000 model use 5 Ampere wire (1.0 sq. mm / Amp). Attach the electrical cable to the red and black connecting points on the PowerPal generator as shown in the following diagram.



*Do not allow electrical contacts to become wet. Use dry hands.
Beware of electrocution.*

9. Hang the electronic load controller (ELC) in a dry place inside the house and connect to the socket end of the cable. Make sure that the red switch on the ELC is in the 'off' position.

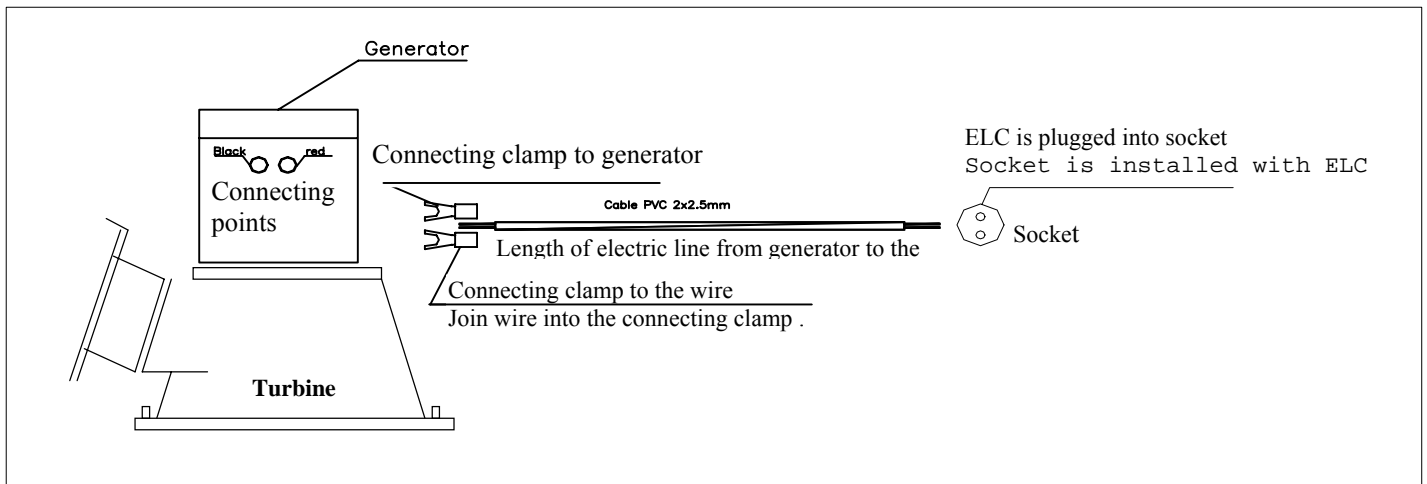

About the electronic load controller

The water turbine captures the water's energy and converts it into electricity. The generator's output voltage is dependent on the load consumption. When there is no power being consumed, the output voltage can reach 280V – 300V. This output voltage will decrease with any increase in power consumption. The electronic load controller is used to eliminate this excess output voltage (>220V) so that it is safe to use household appliances.

10. Now that all wires are properly connected and PowerPal is operating normally, turn the red switch on the ELC to the 'on' position and then turn the white MVR dial clockwise until the voltmeter reads 220V~. Please see the ELC diagram on the following page for further information.
11. You can now plug lights and appliances directly into the ELC ready for use, with or without additional house wiring. The voltage shown on the load controller should still be 220V. The voltage needs only to be checked and adjusted if the water flow rate changes. Heavy rain may increase the flow rate, or a prolonged dry period may gradually reduce it. Check the voltmeter from time to time and adjust the MVR dial if necessary.

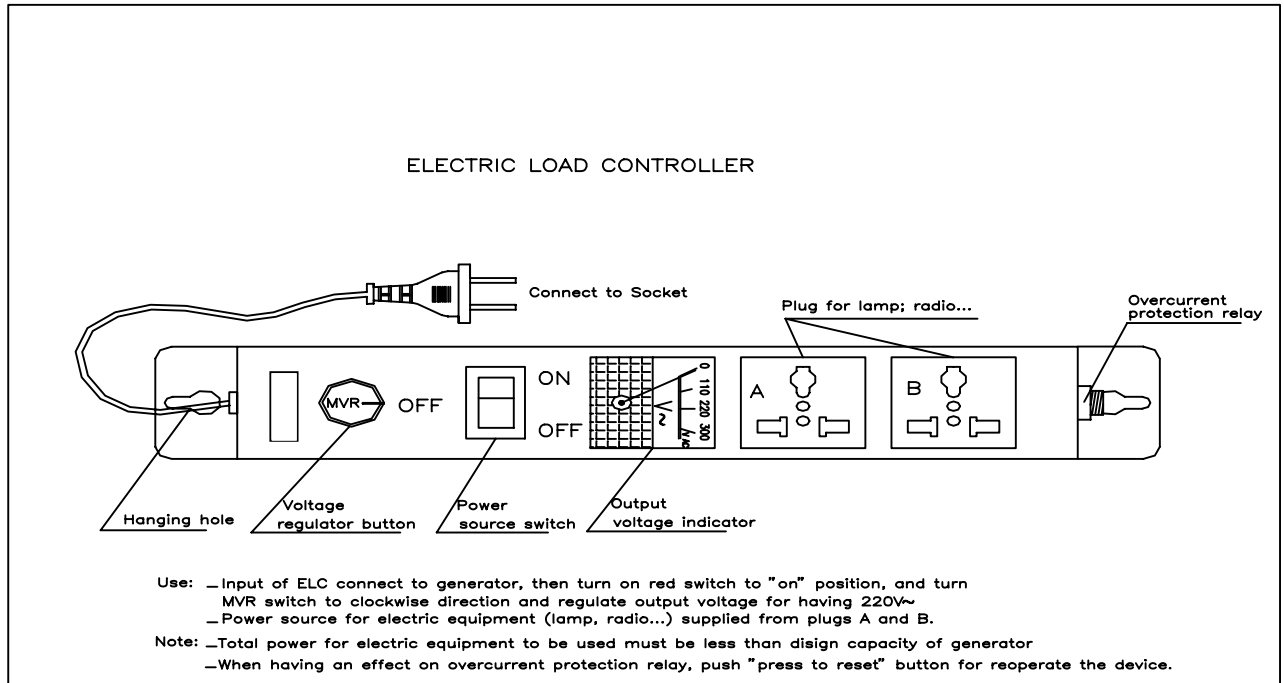

Avoid plugging appliances directly into PowerPal without using the load controller. Incorrect voltage may result, which can damage your appliance.

CARE AND MAINTENANCE

General care for your PowerPal will enhance its life. Following the instructions in this manual is important.

Try to install PowerPal in a place that is unlikely to be flooded. A simple shelter with a roof will also help protect the generator from rain or else a small shed can be built and locked if security is an issue. If the inside of the generator assembly does become wet, remove the cap and leave PowerPal in the sun to dry. No permanent damage will result, but check the bearings to see if they have collected water. If so, turn PowerPal upside down to drain and dry the internal shaft assembly. Do not try to dry it near a fire as the rotor is bonded with epoxy that could be damaged by excessive heat. Before using again, make sure that the power socket is also dry. Condensation inside the generator is normal in tropical areas and will not effect the performance of PowerPal.

There are only two tasks that must be completed at regular intervals. These are the greasing of the lower bearing and the changing of the lower bearing seal.

PowerPal has two bearings, one above the generator and one between the generator and the turbine. The upper bearing is sealed and requires no maintenance. The lower bearing has been greased in the factory ready for use and requires re-greasing every 3 months of continuous use. Two cubic centimeters of grease is enough. Both bearings should be replaced every 3 years or sooner if the water used is particularly sandy.



Failure to change the bearings on time will increase friction and reduce power output. Always dry PowerPal before changing the bearings.



To grease the lower bearing, first turn off all appliances and disconnect the power cable. Drain the forebay so that the water flow stops. Wait till the penstock is drained i.e. little or no water flows out of the turbine. Leave the spear valve open. Unbolt the penstock adaptor flange at the turbine. Keep the penstock away from PowerPal to keep it dry. Then follow these steps:

1. Remove generator cap.
2. Place your hand through the front of the turbine stand, reach up and grip the turbine runner. You should be sure that the runner has stopped rotating before doing this. While holding the runner, unbolt nut on top-center of the rotor. Unbolt clockwise. You can then release the runner.
3. Screw in 2 x M8 bolts into holes in top of rotor, then pull the rotor out. This may require additional effort to overcome the magnet's effects.
4. Remove the runner.
- 5,6,7. Unbolt the generator from the turbine casing.
8. Grease the lower bearing.

When reassembling, repeat the previous steps in reverse. Make sure that all parts are correctly in place and that all bolts are tightened.

There is a black plastic seal below the lower bearing to prevent water entering the shaft as well as to keep the grease inside the lower bearing. Because the axle rotates in the middle of this seal, it is prone to gradual wear and should be replaced every 2 years of continual use. One spare seal is included with your purchase - additional seals for future use are inexpensive and readily obtainable. There is no seal with the upper bearing.



TROUBLESHOOTING

If any problems are encountered, check this section before contacting your Service Center.

1. *Head and flow conditions appear to be OK, but PowerPal will not work.*

It is likely that the system has been installed incorrectly. Check this. If still not working, remove the cap from the generator and use your fingers to quickly turn the nut on top of the rotor. If the rotor begins to spin freely then PowerPal is working.

2. *PowerPal has provided electricity for a while and suddenly the electricity stops.*

If this instruction manual is not followed and power consumption is too high, or if there is a short circuit in an appliance the over-current protection relay on the electronic load controller will trip. This will stop the electric current. Locate and correct the problem and reset the relay switch.

3. *Testing in the stream showed that PowerPal was capable of producing the rated output power (200W or 500W, depending on model). However, after running the electrical cable to the house this output power was found to be less.*

Due to resistance from the cable, long cable runs will result in a small loss of output power. Power loss over a 100m cable run is approximately 10W. If the loss is greater than this it means that the wrong diameter cable was used.

4. *Power output has been falling recently.*

Falling output suggests that the turbine is rotating more slowly than usual. Make sure that the enough water is entering the forebay and ensure that the source river is adequate for the flow being consumed. Otherwise, check the forebay and penstock filter and clean if necessary. Lastly, check that the runner is free of leaves and other debris and that the lower bearing has enough grease.

5. *Frequency varies too much to safely use an appliance that is rated for use at a specific frequency.*

If an exact frequency is required for frequency-sensitive appliances it will be necessary to attach a battery system.

6. *An appliance is supposed to be grounded (earthed).*

PowerPal is not grounded by its position in the stream. If grounding is required for certain appliances it will be necessary to ground them separately. The usual method is to run a wire from the earth pin to a metal stake in the ground outside – consult your dealer for further details.

TECHNICAL SPECIFICATIONS

| | <u>MHG-200HH</u> | <u>MHG-500HH</u> |
|-----------------------------------|--|--|
| 1 Rated power output | 200W | 500W |
| 2 Maximum allowable load | 250W | 650W |
| 3 Intended voltage | 220V~ | 220V~ |
| 4 Frequency at rated power output | 50-60 Hz | 50-60 Hz |
| 5 Frequency at runaway speed | 70 Hz | 70 Hz |
| 6 Rotor runaway speed | 1400rpm | 1400rpm |
| 7 Weight | 21kg | 24kg |
| 8 Turbine runner type | Turgo | Turgo |
| 9 Runner diameter | 210mm | 210mm |
| 10 Number of buckets | 20 | 20 |
| 11 Bucket diameter | 68mm | 68mm |
| 12 Number of nozzles | 1 | 1 |
| 13 Jet diameter | 28.5mm | 28.5mm |
| 14 Generator | Single phase permanent magnet alternator | Single phase permanent magnet alternator |
| 15 Rotor characteristics | NdFeB 3-pair pole permanent magnet | NdFeB 3-pair pole permanent magnet |
| 16 Stator wire size | 0.5mm | 0.7mm |
| 17 Upper bearing size | SKF6301-2Z | SKF6301-2Z |
| 18 Lower bearing size | 1204 | 1204 |
| 19 Seal size | 17x40x7mm | 20x47x7mm |
| 20 Recommended cable | 0.75 sq.mm/A | 0.75 sq.mm/A |
| 21 Operating temperature | 5 to 50 ° C | 5 to 50 ° C |
| 22 Operating humidity | 0 to 90% | 0 to 90% |

Notes:

1,2. Rated power output is the manufacturer's specified output for the given head and flow conditions. A higher output is possible if the head is greater or the flow is faster than recommended. If the maximum allowable load is exceeded then permanent damage to the stator may occur.

3. Is approximately 220V when the ELC is used.

5,6. Runaway speed is the speed of the rotor if no load is applied. This speed is reduced under load.

18. We recommend SKF brand or similar high quality bearings.

Also, the diagrams and much useful information on pages 7 and 15 are taken from *Micro-hydropower Sourcebook – A Practical Guide to Design and Implementation in Developing Countries*. NRECA, 1986.

Special thanks go to David Willcox of the UK for his invaluable input and suggestions.

APPENDIX A – FOREBAY DESIGN

The instructions given on page 7 of this manual to design the forebay are adequate for most cases. The most important aspects of forebay design are:

- 1) To allow a continual flow of water to the penstock so that the turbine keeps functioning.
- 2) To have sufficient safeguards to prevent sand, vegetation and other debris from entering the penstock which could cause blockages and disrupt the turbine. This includes a safety aspect to keep away children and animals that could possibly be injured by the suction of water entering the penstock.
- 3) To have an easy way to stop the water flow when changing the bearings etc.

The following diagram shows a simple forebay design that may be used to achieve all the above goals.

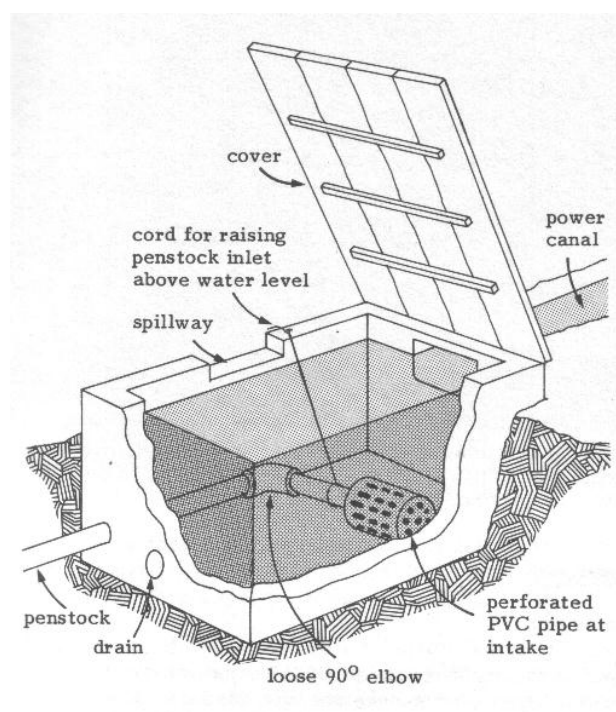

Here, the forebay is made of a waterproofed box situated between the power canal (power conduit) and the penstock. A loosely fitting PVC elbow is inserted between the penstock inlet and the main penstock pipe. Flow to the penstock is cut off by pulling the cord so that the inlet is out of the water. The plugged drain is used to periodically empty out sand and leaves or else this can be shoveled out. The perforated pipe end further reduces litter intake. Here the number and size of holes are important so that flow is not obstructed. For 110mm PVC pipe there should be 110 drilled holes of 12mm diameter.

The box need only be say 40cm x 40cm x 40cm and may be locked to keep away children etc.

DECLARATION OF CONFORMITY

We,

Asian Phoenix Resources Ltd.
2-416 Dallas Road
Victoria, BC V8V 1A9
Canada

Declare that the products described within are, in accordance with Directive 73/23/EEC – the Low Voltage Directive, in conformity with the following standards:

EN 61116:1995 Electromechanical equipment guide for small hydroelectric installations
and
EN 61362:1998 Guide to specification of hydroturbine control systems.



G. Whalan
Authorized signatory

25th March, 2003